

# RUSH™ Scanner 1 LED

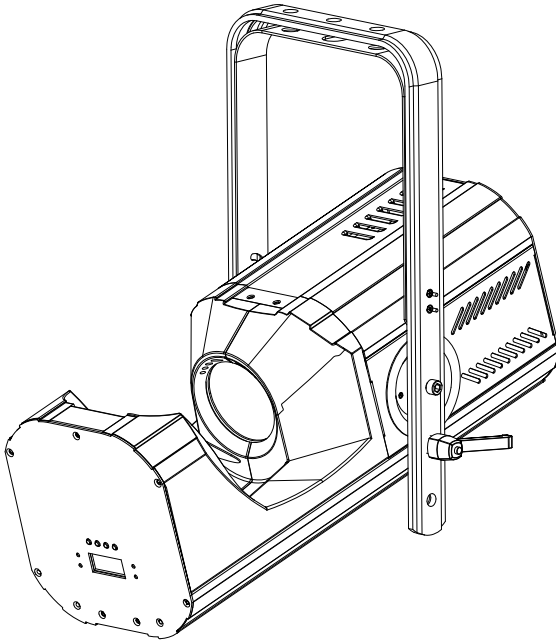

## User Manual



© 2016 Martin Professional™ ApS. Information subject to change without notice. Martin Professional™ and all affiliated companies disclaim liability for any injury, damage, direct or indirect loss, consequential or economic loss or any other loss occasioned by the use of, inability to use or reliance on the information contained in this manual. Martin™, Harman™ and all other trademarks in this document pertaining to services or products by Martin Professional™ or its affiliates and subsidiaries are registered as the property of Harman International Industries.

Martin Professional • Olof Palmes Allé 18 • 8200 Aarhus N • Denmark • [www.martin.com](http://www.martin.com)

RUSH™ Scanner 1 LED User Manual – Revision B

# Table of contents

Safety information .....	4
Introduction .....	9
Before using the product for the first time .....	9
Fixture overview .....	10
Physical installation.....	12
Installing a mounting bracket .....	12
Mounting the fixture on a truss.....	13
Fastening the fixture to a flat surface .....	15
AC power .....	16
Control data link .....	18
Tips for reliable data transmission .....	18
Connecting the DMX data link.....	18
Fixture setup .....	20
Using the control menus .....	20
DMX settings .....	20
Effects settings .....	23
Calibration settings.....	24
Service functions .....	25
Other settings .....	25
Effects .....	26
Electronic dimming.....	26
Gobos.....	26
Color wheels.....	26
Focus.....	27
Prism .....	27
Strobe effects .....	27
Pan and tilt .....	27
Maintenance .....	28
Cleaning .....	28
Fuse replacement.....	29
DMX protocol .....	30
Control menus.....	36
Troubleshooting .....	38
Specifications.....	40

# Safety information



## WARNING!

**Read the safety precautions in this manual before installing, operating or servicing this product.**

The following symbols are used to identify important safety information on the product and in this manual:



**Warning!**

**Safety hazard. Risk of severe injury or death.**



**Warning!**

**Powerful light emission. Risk of eye injury.**



**Warning!**

**See user manual for important safety information.**



**Warning!**

**Hazardous voltage. Risk of lethal or severe electric shock.**



**Warning!**

**Hot surfaces.**



**Warning!**

**Fire hazard.**



**Warning! Risk Group 2 product according to EN 62471. Do not look directly into the beam. Do not view the light output with optical instruments or any device that may concentrate the beam.**

This lighting fixture is for professional use only and must be installed by a qualified technician. It is not for household use. It presents risks of severe injury or death due to fire hazards, electric shock and falls. It produces a powerful, concentrated beam of light that can create a fire hazard or a risk of eye injury if the safety precautions below are not followed.



Install, operate and service Martin™ products only as directed in their user manuals, or you may create a safety hazard or cause damage that is not covered by product warranties.

Follow the safety precautions listed below and observe all warnings in this manual and printed on the product. Keep this user manual for future use.

For the latest user documentation and other information for this and all Martin™ products, please visit the Martin website at <http://www.martin.com>

If you have any questions about how to install, operate or service the fixture safely, please contact your Martin™ distributor (see [www.martin.com/distributors](http://www.martin.com/distributors) for details) or call the Martin™ 24-hour service hotline on +45 8740 0000, or in the USA on 1-888-tech-180.

Respect all locally applicable laws, codes and regulations when installing, operating or servicing the fixture.



### **Protection from electric shock**

Do not expose the fixture to rain or moisture.

Disconnect the fixture from AC power before carrying out any installation or maintenance work and when the fixture is not in use.

Ensure that the fixture is electrically connected to ground (earth).

Use only a source of AC power that complies with local building and electrical codes and has both overload and ground-fault (earth-fault) protection.

Socket outlets or external power switches used to supply the fixture with power must be located near the fixture and easily accessible so that the fixture can easily be disconnected from power.

Replace defective fuses with ones of the specified type and rating only.

Isolate the fixture from power immediately if the power plug or any seal, cover, cable, or other component is damaged, defective, deformed, wet or showing signs of overheating. Do not reapply power until repairs have been completed.

Before using the fixture, check that all power distribution equipment and cables are in perfect condition and rated for the electrical requirements of all connected devices.

Use only Neutrik PowerCon cable connectors to connect to the fixture's power sockets.

Do not connect devices to power in a chain that will exceed the electrical ratings of any cable or connector used in the chain.

The supplied power input cable is rated 6 A and can safely supply only one fixture with mains power. Do not connect any device to the fixture's MAINS OUT connector when using this cable. If you replace this cable and also use the replacement cable to supply only one fixture with mains power, the replacement cable must also be rated 6 A minimum, have three conductors 18 AWG or 0.75 mm<sup>2</sup> minimum conductor size, have an outer cable diameter of 6 - 15 mm (0.2 - 0.6 in.) and be temperature-rated to suit the application. In the USA and Canada the cable must be UL listed, type SJT or equivalent. In the EU the cable must be type H05VV-F or equivalent.

To connect fixtures to mains power in a chain, you must first obtain 14 AWG or 1.5 mm<sup>2</sup> power input and throughput cables that are 16 A rated and temperature-rated to suit the application. In the USA and Canada the cables must be UL-listed, type SJT or equivalent. In the EU the cables must be type H05VV-F or equivalent. Suitable cables with Neutrik PowerCon connectors are available from Martin™ (see 'Accessories' on page 42). If you use these cables, you can connect fixtures to power in a linked chain, MAINS OUT throughput socket to MAINS IN input socket, but do not link more than:

- eight (8) RUSH™ Scanner 1 LEDs in total at 100-120 V, or
- sixteen (16) RUSH™ Scanner 1 LEDs in total at 200-240 V.

The voltage and frequency at the MAINS OUT socket are the same as the voltage and frequency applied to the MAINS IN socket. Only connect devices to the MAINS OUT socket that accept this voltage and frequency.



### **Protection from burns and fire**

Do not operate the fixture if the ambient temperature ( $T_a$ ) exceeds 40° C (104° F).



The surface of the product casing can reach up to 45° C (113° F) during operation. Avoid contact by persons and materials. Allow the fixture to cool for at least 10 minutes before handling.

Keep flammable materials well away from the fixture. Keep all combustible materials (e.g. fabric, wood, paper) at least 100 mm (4 in.) away from the fixture.

Ensure that there is free and unobstructed airflow around the fixture. Provide a minimum clearance of 100 mm (4 in.) around fans and air vents.

Do not illuminate surfaces within 200 mm (8 in.) of the fixture.

Do not attempt to bypass thermostatic switches or fuses.

Do not stick filters, masks or other materials onto any optical component.



### **Protection from eye injury**

The light from the LED lamp is possibly hazardous and may be harmful to the eyes. Do not stare directly into the product's light output.



Do not look at the light output with magnifiers, telescopes, binoculars or similar optical instruments that may concentrate the light output.

Ensure that persons are not looking directly into the LEDs when the product lights up suddenly. This can happen when power is applied, when the product receives a DMX signal, or when certain control menu items are selected.

To minimize the risk of eye irritation or injury, disconnect the fixture from power at all times when the fixture is not in use, and provide well-lit conditions to reduce the pupil diameter of anyone working on or near the fixture.



### **Protection from injury**

Fasten the fixture securely to a fixed surface or structure when in use. The fixture is not portable when installed.

Ensure that any supporting structure and/or hardware used can hold at least 10 times the weight of all the devices they support.

If suspending from a rigging structure, fasten the fixture to a rigging clamp. Do not use safety cables as the primary means of support.

If the fixture is installed in a location where it may cause injury or damage if it falls, install as directed in this manual a secondary attachment such as a safety cable that will hold the fixture if a primary attachment fails. The secondary attachment must be approved by an official body such as TÜV as a safety attachment for the weight that it secures, must comply with EN

60598-2-17 Section 17.6.6 and must be capable of bearing a static suspended load that is ten times the weight of the fixture and all installed accessories.

Check that all external covers and rigging hardware are securely fastened.

Do not operate the fixture with missing or damaged covers, shields or any optical component.

Block access below the work area and work from a stable platform whenever installing, servicing or moving the fixture.

In the event of an operating problem, stop using the fixture immediately and disconnect it from power. Do not attempt to use a fixture that is obviously damaged.

Do not modify the fixture or install other than genuine Martin™ parts.

Refer any service operation not described in this manual to a qualified technician.



# Introduction

The RUSH™ Scanner 1 LED is a powerful scanner with a 90 W long-life LED engine. It features two gobo wheels—one with six rotating gobos and one with seven fixed gobos—and two color wheels, each with eight colors and an open position. It also provides smooth electronic dimming, a rotating prism, motorized focus, and strobe effects. The fixture is rugged, lightweight and compact.

The RUSH™ Scanner 1 LED can be controlled by any DMX-compliant controller. It can also be used as a standalone device running any of its nine pre-programmed shows with a sound activation option that uses the music beat to trigger scenes.

The fixture is supplied with this user manual, a 1.5 m (5 ft.) power cable (local power plug not included), and two mounting brackets.

## Before using the product for the first time

1. Read 'Safety information' on page 4 before installing, powering, operating or servicing the fixture.
2. Unpack and ensure that there is no transportation damage before using the fixture. Do not attempt to operate a damaged fixture.
3. If the fixture is not going to be hard-wired to a mains supply, install a local power plug (not supplied) to the end of the supplied power cable.
4. Ensure that the voltage and frequency of the power supply match the power requirements of the fixture.
5. Check the support pages on the Martin Professional website at [www.martin.com](http://www.martin.com) for the most recent user documentation and technical information about the fixture. Martin™ user manual revisions are identified by the revision letter at the bottom of the inside cover.

Note that whenever AC power is applied to the fixture, it will reset all effects and functions to their home positions. This process usually takes around 20 seconds.

# Fixture overview

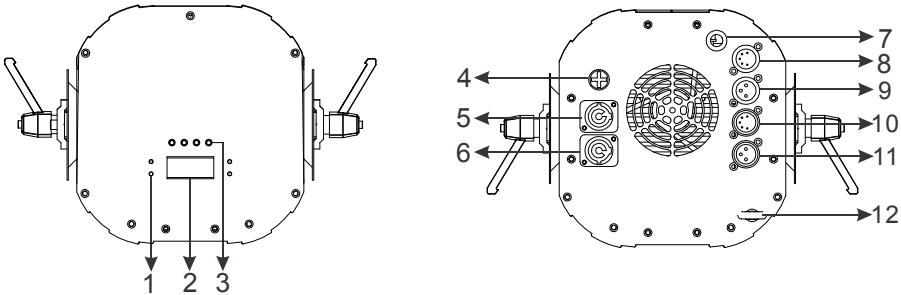

## 1 – Status LEDs

The LEDs on the top end panel indicate the following:

LED	State	Indication
DMX	On	DMX input present
MASTER	On	Fixture set to Master
SLAVE	On	Fixture set to Slave
SOUND	Flashing	Sound activation (music trig)

## 2 – Display

During DMX-controlled operation, the display shows the fixture's DMX address. The address flashes if the DMX signal is lost. In standalone operation, the display shows the number of the selected standalone show.

## 3 – Buttons

- MENU: Press to activate the menu. Within the menu, press to escape and return to the previous level. Press and hold to exit the menu.
- DOWN: Press to scroll down through menu options.
- UP: Press to scroll up through menu options.
- ENTER: Press to confirm and save the menu selection.

## 4 – Fuse

The fixture's T 6.3 A fuse is located in a fuse holder next to the power input/output connectors.

## 5 – AC mains power IN

Connect mains power to the blue Neutrik PowerCon input socket.

## **6 – AC mains power OUT**

The white Neutrik PowerCon socket can be used to supply power to other fixtures only if you respect the safety precautions given in this manual (see 'Safety information' on page 4).

## **7 – Microphone**

Built-in microphone for sound-activated scene changes in show mode.

## **8, 9, 10, 11 – DMX input/output sockets**

For your convenience, both 3-pin and 5-pin XLR sockets are provided for DMX input and output (throughput). Connect suitable DMX data cables to only one input and only one output.

## **12 – Secondary attachment point**

Loop a secondary attachment such as an approved safety cable that is rated for the weight of the fixture through the eye bolt provided for this purpose. Do not use the mounting bracket for secondary attachment.

# Physical installation



**Warning! Read ‘Safety information’ on page 4 before installing the fixture.**

The fixture is designed for indoor use only and must be used in a dry location with adequate ventilation. Ensure that none of the fixture’s ventilation slots are blocked.

Fasten the fixture to a secure structure or surface. Do not stand it unsecured on a surface or leave it where it can be moved or fall over. If you install the fixture in a location where it may cause injury or damage if it falls, secure it as directed in this user manual using a securely anchored safety cable that will hold the fixture if the primary fastening method fails.

Martin™ can supply safety cables and rigging clamps that are suitable for use with the fixture (see ‘Accessories’ on page 42).

## Installing a mounting bracket

The RUSH™ Scanner 1 LED is supplied with two mounting brackets: a short bracket for installation close to the truss, and a long, folding bracket with two mounting positions that allow for vertical installation. See also page 14.

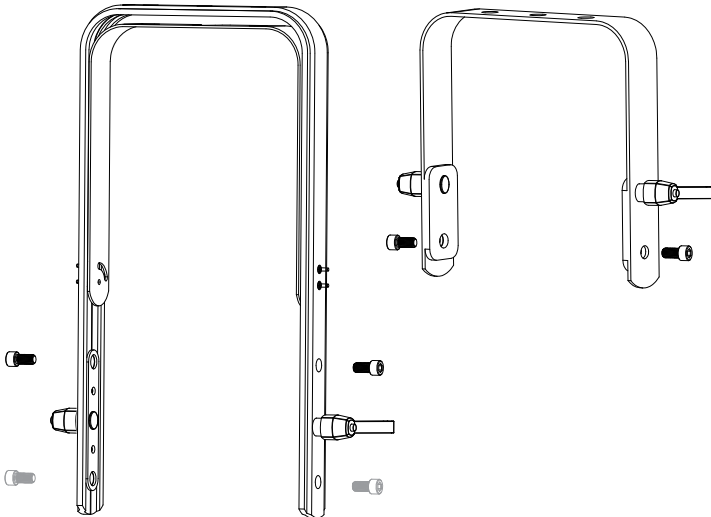

*Long and short mounting brackets*

A 6 mm hex (Allen) key is required to install the mounting bracket. To install the bracket:

1. If installed, remove the hex socket screws that fasten the bracket to the fixture.
2. Loosen the locking levers on each side of the bracket.
3. Align the mounting holes on the bracket with the mounting holes on the fixture. If using the long bracket, select the holes above the locking handles for installation closer to the truss, or the holes below the locking handles for installation farther from the truss.
4. On each side, insert the hex socket screws through the bracket and into the fixture. Tighten securely.

### **Mounting the fixture on a truss**

The fixture can be clamped to a truss or similar rigging structure. Use a suitable rigging clamp such as a G-clamp or a half-coupler clamp fastened to the mounting bracket. You may use a G-clamp only if the fixture will hang vertically from the clamp when installed. In all other installations, use a half-coupler clamp (see illustration on right).



To clamp the fixture to a truss:

1. Check that the rigging structure can support at least 10 times the weight of all fixtures and equipment to be installed on it.
2. Block access under the work area.
3. Bolt a suitable rigging clamp through the center hole of the mounting bracket. If using the long bracket, fasten the clamp to outer bracket. The bolt used must be M12, grade 8.8 steel minimum, and fastened with a self-locking nut.
4. Working from a stable platform, hang the fixture on the truss and fasten the rigging clamp onto the truss.
5. Adjust the angle of the fixture and tighten both locking handles.
6. Secure the fixture with a safety cable as directed below.

### **Securing with a safety cable**

Secure the fixture with a safety cable (or other secondary attachment) that is approved for the weight of the fixture so that the safety cable will hold the fixture if the primary attachment fails. Loop the safety cable through the eye bolt on the rear plate and around a secure anchoring point as shown on next page.

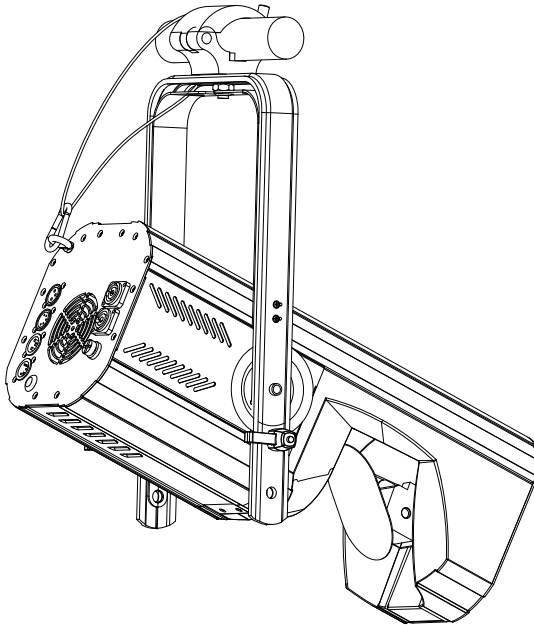
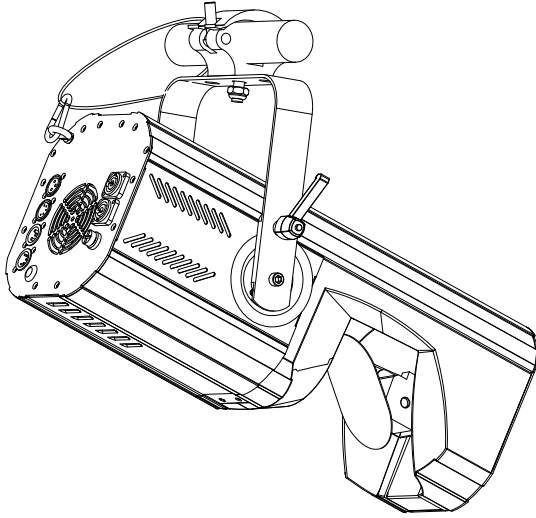

*Rigging with short and long brackets*

## **Fastening the fixture to a flat surface**

The long bracket may also be used to fasten the fixture to a hard, fixed, flat surface that is oriented at any angle. The inner bracket may be folded out for additional stability.

Ensure that the surface and all fasteners used can support at least 10 times the weight of all fixtures and equipment they will support.

Fasten the fixture securely. Do not stand it on a surface or leave it where it can be moved or fall over. If you install the fixture in a location where it may cause injury or damage if it falls, secure it as directed below with a securely anchored safety cable that will hold the fixture if the primary fastening method fails.

# AC power



**Warning!** Read 'Safety information' on page 4 before connecting the fixture to AC mains power.



**Warning!** The mains power input cable supplied with the fixture is rated 6 A and can supply only one fixture with mains power. Do not connect any device to the fixture's MAINS OUT power throughput socket when using this input cable. If you want to connect other fixtures to the MAINS OUT socket, see 'Linking fixtures to power in a chain' on page 17.

For protection from electric shock, the fixture must be grounded (earthed). The power distribution circuit must be equipped with a fuse or circuit breaker and ground-fault (earth-fault) protection.

Socket outlets or external power switches used to supply the fixture with power must be located near the fixture and easily accessible so that the fixtures can easily be disconnected from power.

Do not insert or remove live Neutrik PowerCon connectors to apply or cut power, as this may cause arcing at the terminals that will damage the connectors.

Do not use an external dimming system to supply power to the fixture, as this may cause damage to the fixture that is not covered by the product warranty.

The fixture can be hard-wired to a building electrical installation if you want to install it permanently, or a power plug (not supplied) that is suitable for the local power outlets can be installed on the power cable.

If you install a power plug on the power cable, install a grounding type (earthed) plug with integral cable grip that is rated minimum 250 V, 6 A. Follow the plug manufacturer's instructions and connect the wires in the power cable as shown in this table:

	<b>Live or L</b>	<b>Neutral or N</b>	<b>Earth, Ground or ⊕</b>
<b>US system</b>	Black	White	Green
<b>EU system</b>	Brown	Blue	Yellow/green



The fixture has an auto-ranging power supply that accepts AC mains power at 100-240 V at 50/60 Hz. Do not apply AC mains power at any other voltage or frequency to the fixture.

### **Linking fixtures to power in a chain**

If you obtain a 14 AWG or 1.5 mm<sup>2</sup> power input cable and 14 AWG or 1.5 mm<sup>2</sup> throughput cables from Martin™ (see 'Accessories' on page 42), you can relay mains power from one fixture to another by connecting fixtures to power in a linked daisy-chain, MAINS OUT throughput socket to MAINS IN input socket.

Using 14 AWG or 1.5 mm<sup>2</sup> cables from Martin™, you can link:

- Maximum eight (8) RUSH™ Scanner 1 LED fixtures in total at 100-120 V, or
- Maximum sixteen (16) RUSH™ Scanner 1 LED fixtures in total at 200-240 V.

If you install a power plug on the 14 AWG / 1.5 mm<sup>2</sup> power input cable, install a grounding type (earthed) plug with integral cable grip that is rated minimum 16 A, 250 V.

# Control data link

A DMX 512 data link is required in order to control the fixture via DMX. The fixture has 3-pin and 5-pin XLR connectors for DMX data input and output.

Up to 32 devices can be linked together on a single daisy chain. The total number of fixtures in one 512-channel DMX universe is limited by the number of DMX channels required by the fixtures. Note that if independent control of a fixture is required, it must have its own DMX channels. Fixtures that are required to behave identically can share the same DMX address and channels. To add more fixtures or groups of fixtures when the above limits are reached, add a DMX universe and/or split the daisy-chained link into branches.

## Tips for reliable data transmission

Use shielded twisted-pair cable designed for RS-485 devices: standard microphone cable cannot transmit control data reliably over long runs. 24 AWG cable is suitable for runs up to 300 meters (1000 ft.). Heavier gauge cable and/or an amplifier is recommended for longer runs. The pin-out on all connectors is pin 1 = shield, pin 2 = cold (-), and pin 3 = hot (+). Pins 4 and 5 in the 5-pin XLR connectors are not used in the fixture but are available for possible additional data signals as required by the DMX512-A standard. Standard pin-out is pin 4 = data 2 cold (-) and pin 5 = data 2 hot (+).

To split the link into branches, use an opto-isolated splitter such as the Martin™ DMX 5.3 Splitter. Terminate the link by installing a termination plug in the output socket of the last fixture. The termination plug, which is a male XLR plug with a 120 Ohm, 0.25 Watt resistor soldered between pins 2 and 3, “soaks up” the control signal so it does not reflect and cause interference. If a splitter is used, terminate each branch of the link.

## Connecting the DMX data link

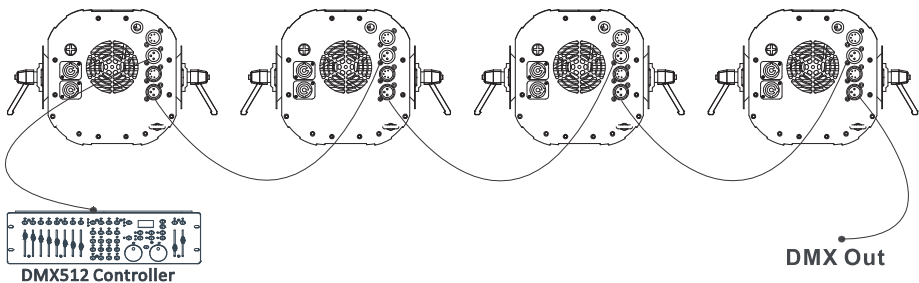

To connect the fixture to data:

1. Connect the DMX data output from the controller to the first fixture's male 3-pin or 5-pin XLR DMX input connector.
2. Connect the first fixture's DMX output to the DMX input of the next fixture and continue connecting fixtures output to input.
3. Terminate the last fixture on the link with a DMX termination plug.

# Fixture setup

This section explains the fixture characteristics that can be set that determine how it can be controlled and will behave. These settings are made using the menus available from the control panel and are retained when the fixture is powered off. Only the most commonly used menu options are described in this section. A complete map of the control menu structure and brief explanations of their purposes can be found in 'Control menus' on page 36.

## Using the control menus

During normal operation, the display shows the fixture's DMX address or the selected standalone show. To access the control menus, press the MENU button.

- Navigate the menu structure using the ENTER, DOWN and UP buttons.
- To select a menu option or to confirm a selection, press ENTER.
- To return to a higher level in the menu structure without making a change, press MENU.
- To exit the control menus completely, press and hold MENU.

## DMX settings

### *DMX address*

The RUSH™ Scanner 1 LED uses 16 DMX channels. The DMX address, also known as the start channel, is the first channel used to receive instructions from a DMX controller. Each DMX controlled fixture must have a DMX address set. For example, if a fixture has a DMX address of 10, then it uses channels 10 through 25. The following fixture in the DMX chain can then be set to a DMX address of 26.

For independent control, each fixture must be assigned its own control channels. Two fixtures of the same type may share the same address if identical behavior is desired. Address sharing can be useful for diagnostic purposes and symmetric control, particularly when combined with the inverse pan and tilt options.

To set the fixture's DMX address:

1. Enter the control menu and select DMX ADDRESS. Press ENTER. The current address setting will blink on the display.
2. Use the UP and DOWN buttons to select an address from 1 to 497.
3. Press ENTER to confirm your selection.

### ***Behavior without DMX (DMX State)***

The DMX STATE setting determines how the fixture behaves when it is not receiving a DMX signal. You can set the fixture to enter Show Mode, black out, or hold the effect it was displaying when the DMX signal stopped. The fixture is set to BLACKOUT by default.

To adjust the setting:

1. Select DMX STATE and press ENTER.
2. Use the DOWN and UP buttons to select SHOW MODE (fixture enters Show Mode), BLACKOUT (fixture blacks out) or HOLD (fixture shows the last effect it was displaying before the DMX signal stopped).
3. Press ENTER to save your selection.

### **Standalone settings**

The fixture will operate in standalone mode if it is not receiving a DMX signal and the DMX STATE menu option is set to SHOW MODE (see above), or if you enter the SHOW MODE menu in the control panel.

#### ***Standalone show selection (Show Mode)***

Nine pre-programmed standalone shows are available. To set the show that the fixture will run in Show Mode:

1. Select SHOW MODE and press ENTER.
2. Use the DOWN and UP buttons to select a show from 0 to 8.
3. Press ENTER to save your selection.

#### ***Master/Slave mode***

You can synchronize the standalone shows of fixtures on a data link using Master/Slave mode. In this mode, a master fixture runs a preprogrammed or sound-activated standalone show and the other fixtures run a standalone show that is either identical to or synchronized with the first fixture.

To set up Master/Slave operation:

1. Check that fixtures are linked in a chain with a DMX data cable.
2. Set all fixtures in the chain to DMX STATE → SHOW MODE, and make sure that no DMX signal is present on the data link. On one – and only one – fixture on the link, open the MASTER SLAVE menu and use the UP and DOWN buttons to set the fixture to MASTER. All the other fixtures must be set to act as slaves. Fixtures' MASTER and SLAVE LEDs light to indicate which mode they are operating in.

3. On the slave fixtures, open the MASTER SLAVE menu and use the UP and DOWN buttons to select from:
  - **Slave 1** – fixture runs the same show as the master fixture, or
  - **Slave 2** – fixture runs a show that is synchronized with the master fixture but is not identical to the master fixture's show.
4. Press ENTER to confirm your selection.
5. Select a pre-programmed standalone show on the master fixture as described above.

### ***Sound activation (music trig)***

The fixture's built-in sound activation microphone can be used to trigger scene changes with a music beat or other sound source when a fixture is running a standalone show.

To set a chain of fixtures in Master/Slave mode to sound activation, you only need to set up the Master fixture. Slave fixtures will synchronize with the master fixture.

When sound activation is running, the SOUND status LED on the control panel flashes in sync with the music beat.

To set sound activation:

1. Select SOUND MODE and press ENTER to confirm. The current setting will blink in the display.
2. Use the DOWN and UP buttons to select ON (sound activation enabled) or OFF (sound activation disabled).
3. Press ENTER to confirm your selection.

### ***Sound activation microphone sensitivity***

To adjust the sensitivity of the sound activation microphone:

1. Play some typical music at the normal volume for the venue.
2. Select SOUND SENSE and press ENTER to confirm. The current setting will blink on the display.
3. Use the DOWN and UP buttons to change the microphone sensitivity from 0 ...100 until the fixture responds well to the music beat.
4. Press ENTER to confirm your selection.

## Focus

Focus during standalone shows can be set for each gobo wheel: wheel 1 (rotating gobos) and wheel 2 (fixed gobos).

To set the focus for the rotating gobo wheel:

1. Select FOCUS ADJUST and press ENTER.
2. Use the DOWN and UP buttons to change the focus point from 0 to 255.
3. Press ENTER to confirm the selected focus point.

To set the focus for the fixed gobo wheel:

1. Select FOCUS 2 ADJUST and press ENTER to confirm.
2. Use the DOWN and UP buttons to change the focus point from 0 to 255.
3. Press ENTER to confirm the selected focus point.

## Effects settings

### Dimming curves

The fixture has four dimming modes as shown below. The default is MODE 2.

- MODE 1    LINEAR. The increase in light intensity appears to be linear as DMX value is increased.
- MODE 2    SQUARE LAW – light intensity control is finer at low levels and coarser at high levels.
- MODE 3    INVERSE SQUARE LAW – light intensity control is coarser at low levels and finer at high levels.
- MODE 4    S-CURVE – light intensity control is finer at low levels and high levels and coarser at medium levels.

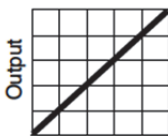

Optically linear

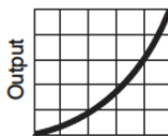

Square law

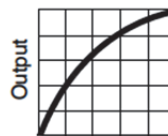

Inverse square law

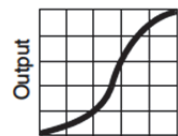

S-curve

To set the fixture's dimmer curve:

1. Select DIMMER CURVE and press ENTER to confirm.
2. Use the DOWN and UP buttons to select Mode1, Mode 2, Mode 3 or Mode 4.
3. Press ENTER to save your selection.

## ***Dimmer Speed***

You can optimize the dimmer for speed (default) or for smoothness.

To optimize the dimmer:

1. Select DIMMER SPEED and press ENTER.
2. Select FADE for smoother dimming or SNAP for faster dimming.
3. Press ENTER to confirm your selection.

## ***Pan/tilt inversion***

The PAN INVERSE and TILT INVERSE menus can be used to reverse the direction of pan and tilt. These settings are useful for symmetrical effects with multiple fixtures, or when coordinating the movement of fixtures that are floor mounted and rigged upside down.

To adjust the pan or tilt inversion settings:

1. Select PAN INVERSE or TILT INVERSE and press ENTER.
2. Select the YES to reverse pan or tilt control or NO for normal control.
3. Press ENTER to confirm your selection.

## **Calibration settings**

### ***Dimmer calibration***

You can use dimmer calibration to set the maximum light output level during standalone operation or to match output levels across multiple fixtures. To set dimmer calibration:

1. Power the fixture on (if matching multiple fixtures, aim them so that their projections are side-by-side).
2. Select DIMMER CALIBRATE and press ENTER.
3. Using the DOWN and UP buttons, change the value from 50 ...100 to adjust the maximum light level.
4. Press ENTER to confirm the maximum light level.

### ***Effect home position adjustment***

The effects (pan, tilt, color wheels, gobo wheels, gobos, focus, and prism) can lose their indexed home position. To reset any of these:

1. In the menu structure, press and hold ENTER for at least 3 seconds to enter the OFFSET MENU (see '**Offset adjustment**' on page 37).
2. Use the DOWN and UP buttons to scroll to the effect you want to adjust. Press ENTER to select it.
3. Use the DOWN and UP buttons to adjust, then press ENTER to set (or press MENU to exit without making a change).



## **Service functions**

### ***Auto test***

To perform a complete test of all of the fixture functions:

1. Select AUTO TEST and press ENTER.
2. Press ENTER again. The fixture will run a self-test routine.
3. Press MENU to exit the test.

### ***Reset effects***

To reset all effects to their home positions, select RESET and press ENTER.

### ***Factory default settings***

To return all the settings in the control menu to their factory defaults, cancelling any changes made by users:

1. Select PRO DEFAULT and press ENTER.
2. Select YES and press ENTER to confirm.

## **Other settings**

### ***Backlight***

Display illumination can be turned on or off. To adjust the backlight settings:

1. Select BACK LIGHT menu and press ENTER.
2. Select ON to illuminate the display or OFF for a dark display.
3. Press ENTER to confirm your selection.

### ***Fan mode***

The fan speed can be optimized for maximum light output (AUTO) or minimum noise (LOW). When LOW is selected, the fan runs more slowly and the LED is dimmed if necessary to reduce temperature. To change the fan setting:

1. Select FAN MODE and press ENTER.
2. Select AUTO if you want to maximize light output or LOW if you want to minimize fan noise.
3. Press ENTER to confirm your selection.

# Effects

This section describes the main effects that you can control via DMX. See 'DMX protocol' on page 30 for a full list of DMX channels, DMX values and control possibilities.

## Electronic dimming

Overall intensity can be adjusted 0-100%.

## Gobos

The fixture contains two gobo wheels:

**Gobo wheel 1 (rotating gobos)\***

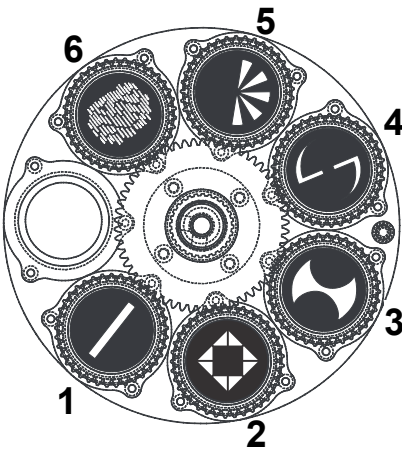

**Gobo wheel 2 (fixed gobos)**

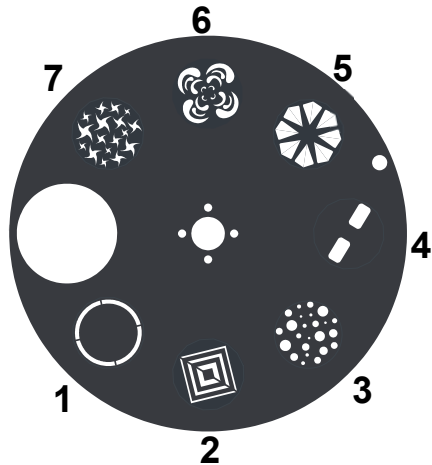

*\*Gobo wheel 1 shown from front lens side.  
Images will be flipped left-right when projected.*

Individual gobos on wheel 1 can be rotated clockwise and counter-clockwise, and a gobo shake function is available. Any gobo can be projected statically. Both gobo wheels can be rotated clockwise and counter-clockwise.

## Color wheels

The fixture incorporates two color wheels, each with eight colors and open/white. These can be individually selected, or the wheels can be rotated at varying speeds, both clockwise and counter-clockwise.

## **Focus**

The motorized focus allows you to adjust the sharpness of gobo projections. Changing focus from one gobo wheel to the other creates morphing effects.

## **Prism**

The fixture incorporates a prism than can be inserted into the beam, providing split effects. The prism can be set to an indexed position or rotated clockwise or counter-clockwise.

## **Strobe effects**

The strobe effects provide instant open and blackout, variable speed regular and random strobe.

## **Pan and tilt**

The fixture's mirror can be panned through 170° and tilted through 75° using coarse and fine control channels.

# Maintenance



**Warning! Read ‘Safety information’ on page 4 before servicing the fixture.**

Service fixtures in an area where there is no risk of injury from failing parts, tools or other materials.

Refer any service or repair operation not described in this manual to an authorized Martin™ service technician. Do not try to carry out such an operation yourself, as doing so may present a health or safety risk. It may also cause damage or malfunction, and it may void your product warranty.

Installation, on-site service and maintenance can be provided worldwide by the Martin Professional Global Service organization and its approved agents, giving owners access to Martin’s expertise and product knowledge in a partnership that will ensure the highest level of performance throughout the product’s lifetime. Please contact your Martin™ supplier for details.

## Cleaning

Excessive dust, smoke fluid, and particle buildup degrades performance, causes overheating and will damage the fixture. Damage caused by inadequate cleaning or maintenance is not covered by the product warranty.

The cleaning of external optical lenses must be carried out periodically to optimize light output. Cleaning schedules for lighting fixtures vary greatly depending on the operating environment. It is therefore impossible to specify precise cleaning intervals for the fixture. Environmental factors that may result in a need for frequent cleaning include:

- Use of smoke or fog machines.
- High airflow rates (near air conditioning vents, for example).
- Presence of cigarette smoke.
- Airborne dust (from stage effects, building structures and fittings or the natural environment at outdoor events, for example).

If one or more of these factors is present, inspect fixtures within their first 100 hours of operation to see whether cleaning is necessary. Check again at frequent intervals. This procedure will allow you to assess cleaning requirements in your particular situation. If in doubt, consult your Martin dealer about a suitable maintenance schedule.

Use gentle pressure only when cleaning, and work in a clean, well-lit area. Do not use any product that contains solvents or abrasives, as these can cause surface damage and weaken the adhesive that fastens the mirror.

To clean the fixture:

1. Disconnect the fixture from power and allow it to cool for at least 10 minutes.
2. Vacuum or gently blow away dust and loose particles from the outside of the fixture and the air vents with low-pressure compressed air.
3. Clean the mirror and LED lenses by wiping gently with a soft, clean lint-free cloth moistened with a weak detergent solution. Do not rub the surface hard: lift particles off with a soft repeated press. Dry with a soft, clean, lint-free cloth or low-pressure compressed air. Remove stuck particles with an unscented tissue or cotton swab moistened with glass cleaner or distilled water.
4. Check that the fixture is dry before reapplying power.

### **Fuse replacement**

If you need to replace a fuse:

1. Disconnect the fixture from power and allow it to cool for at least 10 minutes.
2. Unscrew the cap of the fuse holder (shown on page 10) and remove the fuse. Replace with a fuse of the same size and rating only.
3. Reinstall the fuseholder cap before reapplying power.

# DMX protocol

Chan.	Value	Function
1	0-255	Dimmer, coarse, 0-100%
2	0-255	Dimmer, fine
3	<b>Strobe</b>	
	0-7	Off
	8-15	Open
	16-131	Strobe, slow → fast
	132-167	Fast close, slow open
	168-203	Slow close, fast open
	204-239	Pulse open and close
	240-247	Random strobe
	248-255	Open
4	<b>Color wheel 1</b>	
	<b><i>Continuous scrolling</i></b>	
	0	White
	1-14	White → Red
	15	Red (Color 1)
	16-29	Red → Deep Blue
	30	Deep Blue (Color 2)
	31-44	Deep Blue → Lavender
	45	Lavender (Color 3)
	46-59	Lavender → Magenta
	60	Magenta (Color 4)
	61-74	Magenta → Yellow
	75	Yellow (Color 5)
	76-89	Yellow → Orange
	90	Orange (Color 6)
	91-104	Orange → Light Green
	105	Light Green (Color 7)
	106-119	Light Green → Light blue
	120	Light blue (Color 8)
	121-134	Light blue → White
	135-160	White
	<b><i>Stepped scrolling</i></b>	
	161-163	Color 1 - Red
164-166	Color 2 - Deep Blue	
167-169	Color 3 - Lavender	
170-172	Color 4 - Magenta	

Chan.	Value	Function
4	173-175	Color 5 - Yellow
	176-178	Color 6 - Orange
	179-181	Color 7 - Light Green
	182-184	Color 8 - Light blue
	185-192	White
		<b>Continuous rotation</b>
	193-214	Clockwise, fast → slow
	215-221	Stop
	222-243	Counter-clockwise, slow → fast
		<b>Random color</b>
	244-247	Fast
	248-251	Medium
252-255	Slow	
5		<b>Color wheel 2</b>
		<b>Continuous scrolling</b>
	0	White
	1-14	White → Pink
	15	Pink (Color 1)
	16-29	Pink → CTO 3200K
	30	CTO 3200K (Color 2)
	31-44	CTO 3200K → UV Purple
	45	UV Purple (Color 3)
	46-59	UV Purple → Light Yellow
	60	Light Yellow (Color 4)
	61-74	Light Yellow → Green
	75	Green (Color 5)
	76-89	Green → Aquamarine
	90	Aquamarine (Color 6)
	91-104	Aquamarine → CTO 5600K
	105	CTO 5600K (Color 7)
	106-119	CTO 5600K → Blue
	120	Blue (Color 8)
	121-134	Blue → White
	135-160	White
		<b>Stepped scrolling</b>
	161-163	Color 1 - Pink
	164-166	Color 2 - CTO 3200K
	167-169	Color 3 - UV Purple
170-172	Color 4 - Light yellow	
173-175	Color 5 - Green	

Chan.	Value	Function
5	176-178	Color 6 - Aquamarine
	179-181	Color 7 - CTO 5600K
	182-184	Color 8 - Blue
	185-192	White
		<b>Continuous rotation</b>
	193-214	Clockwise, fast → slow
	215-221	Stop
	222-243	Counter-clockwise, slow → fast
		<b>Random color</b>
	244-247	Fast
	248-251	Medium
	252-255	Slow
6		<b>Gobo wheel 1 (rotating gobos)</b>
		<b>Gobo selection</b>
	0-4	Open
	5-9	Gobo 1
	10-14	Gobo 2
	15-19	Gobo 3
	20-24	Gobo 4
	25-29	Gobo 5
	30-34	Gobo 6
		<b>Gobo rotation (set direction and speed on channel 7)</b>
	35-39	Gobo 1
	40-44	Gobo 2
	45-49	Gobo 3
	50-54	Gobo 4
	55-59	Gobo 5
	60-64	Gobo 6
		<b>Gobo shake</b>
	65-88	Gobo 1 shake
	89-112	Gobo 2 shake
	113-136	Gobo 3 shake
	137-160	Gobo 4 shake
	161-184	Gobo 5 shake
	185-208	Gobo 6 shake
	209	No function
		<b>Continuous wheel rotation</b>
	210-232	clockwise, fast → slow
	233-255	counter clockwise, slow → fast



Chan.	Value	Function
7	<b>Gobo wheel 1 indexing/rotation</b>	
		<b>Wheel indexing</b>
	0-255	Indexed position, 0°→180°
		<b>Wheel rotation</b>
	0-2	No rotation
	3-126	Clockwise rotation, fast → slow
	127-129	Stop
	130-253	Counter-clockwise rotation, slow → fast
	254-255	Stop
8	<b>Gobo wheel 2 (fixed gobos)</b>	
		<b>Continuous scrolling</b>
	0	Open
	1-14	Open → Gobo1
	15	Gobo 1
	16-29	Gobo 1 → Gobo 2
	30	Gobo 2
	31-44	Gobo 2 → Gobo 3
	45	Gobo 3
	46-59	Gobo 3 → Gobo 4
	60	Gobo 4
	61-74	Gobo 4 → Gobo 5
	75	Gobo 5
	76-89	Gobo 5 → Gobo 6
	90	Gobo 6
	91-104	Gobo 6 → Gobo 7
	105	Gobo 7
	106-119	Gobo 7 → Open
	120-160	Open
		<b>Stepped scrolling</b>
	161-163	Gobo 1
	164-166	Gobo 2
	167-169	Gobo 3
	170-172	Gobo 4
	173-175	Gobo 5
	176-178	Gobo 6
	179-181	Gobo 7
	182-192	Open
	<b>Continuous wheel rotation</b>	
193-214	Clockwise, fast → slow	
215-221	Stop	

Chan.	Value	Function
8	222-243	Counter-clockwise, slow → fast
		<b>Random gobo</b>
	244-247	Fast
	248-251	Medium
	252-255	Slow
9		<b>Prism</b>
	0-10	Open
	11-138	Prism indexing (set angle on channel 10)
	139-255	Prism rotation (set direction and speed on channel 10)
10		<b>Prism indexing / rotation</b>
		<b>Prism indexing angle</b>
	0-255	Indexed position 0° → 180°
		<b>Prism rotation direction and speed</b>
	0-2	No rotation
	3-126	Clockwise rotation, fast → slow
	127-129	Stop
	130-253	Counter-clockwise rotation, slow → fast
	254-255	Stop
11	0-255	Focus, infinity → near
12	0-255	Pan 0° → 170°
13	0-255	Pan (fine control)
14	0-255	Tilt 0° → 75°
15	0-255	Tilt (fine control)
16		<b>Functions / fixture settings</b>
	0-9	<i>No function</i>
	10-14	Reset all
	15-19	Reset color
	20-24	Reset gobo
	25-29	Reset focus
	30-34	Reset prism
	35-39	Reset pan/tilt
	40-54	<i>No function</i>
	55-59	Enable calibration
	60-79	<i>No function</i>
	80-84	Pan/tilt speed = Normal
	85-89	Pan/tilt speed = Fast (default setting)
	90-94	Pan/tilt speed = Slow
	95-99	Parameter shortcuts = On (default setting)
	100-104	Parameter shortcuts = Off

Chan.	Value	Function
<b>16</b>	105-144	<i>No function</i>
	145-149	Blackout = On (fixture goes to standby when no DMX signal)
	150-154	Blackout = Off (default setting: fixture enters standalone operation when no DMX signal)
	155-159	Illuminate control panel display
	160-164	Turn off control panel display
	165-194	<i>No function</i>
	195-199	Store color wheel 1 calibration
	200-204	Store color wheel 2 calibration
	205-209	Store gobo wheel 1 wheel calibration
	210-214	Store gobo wheel 1 gobo calibration
	215-219	Store gobo wheel 2 calibration
	220-224	Store focus calibration
	225-229	Store prism calibration
	230-234	Store prism rotation calibration
	235-239	Store pan calibration
	240-244	Store tilt calibration
	245-249	Reset all calibration settings to factory defaults
	250-255	<i>No function</i>

# Control menus

To access the control menus, press MENU. Press UP and DOWN to navigate the menus. Press ENTER to select a menu option. For more information, see 'Using the control menus' on page 20.

Default fixture settings are shown in **bold**.

Menu	Sub-menu	Explanation
DMX Address	001–512	Fixture DMX address setting
Show Mode	<b>Show 0</b> ...Show 8	Show 0 to 8
Master Slave	Master	Fixture acts as master in master/slave operation
	<b>Slave 1</b>	Fixture copies master in master/slave operation
	Slave 2	Fixture in sync with master in master/slave operation but does not run identical show
Sound Mode	<b>On</b>	Sound activation (music trig)
	Off	No sound activation
Sound Sense	0...100	Microphone sensitivity for sound activation
DMX State	Show Mode	If DMX signal stops, fixture enters show mode
	<b>Blackout</b>	If DMX signal stops, fixture blacks out
	Hold	If DMX signal stops, fixture continues to obey the last command it received via DMX
Dimmer Curve	Mode 1	Optically Linear
	<b>Mode 2</b>	Square law
	Mode 3	Inverse law
	Mode 4	S-curve
Dimmer Speed	Fade	Dimmer optimized for smoothness
	<b>Snap</b>	Dimmer optimized for speed
Dimmer Calibrate	50-100	Dimmer calibration
Back light	On	Control panel display backlight on
	<b>Off</b>	Display backlight off
Pan Inverse	Yes	Invert pan control
	<b>No</b>	Normal pan control

Tilt Inverse	Yes	Invert tilt control
	No	Normal tilt control
Focus Adjust	0–255	Rotating gobo focus (standalone)
Focus 2 Adjust	0–255	Fixed gobo focus (standalone)
Auto test		Automatic test of all functions
LED Temp.		Onboard temperature sensor readout
Fan Mode	Auto	Optimize cooling for light output intensity
	Low	Optimize cooling for quietness (lamp may dim to reduce temperature)
Fixture Time		Fixture operating hour counter
Firmware Version		Current installed firmware version
Pro Default	Yes	Restore factory default settings
	No	
Reset		Reset fixture

## Offset adjustment

The Offset menu is used to adjust the home position of the various effects. To access the Offset menu:

1. Press the MENU button to enter the menu structure.
2. Press and hold the ENTER button for at least three seconds.

Menu	Sub-menu	Setting	Explanation
Offset	Pan	-128 → 127	Pan position
	Tilt	-128 → 127	Tilt position
	Color 1	-128 → 127	Color wheel 1 position
	Color 2	-128 → 127	Color wheel 2 position
	Gobo 1	-128 → 127	Rotating gobo wheel position
	R Gobo 1	-128 → 127	Rotating gobo position
	Gobo 2	-128 → 127	Static gobo wheel position
	Prism	0 → 255	Prism indexed position
	R prism	-128 → 127	Prism rotation position
	Focus	0 → 255	Focus position

# Troubleshooting

This section describes a few problems that you may have during operation and provides some suggestions for troubleshooting:

Symptom	Potential cause	Remedies
No light from fixture, or fans not working.	Power supply issue, such as blown fuse, faulty connector or damaged cable.	Ensure that the mains supply is connected and supplying power to the fixture. Check all power connections and cables. Replace the fixture fuse.
The fixture does not react to the beat of music.	Sound activation disabled. Sound activation sensitivity too low for music source.	Ensure that the fixture is not connected to a DMX signal. Adjust sound activation microphone sensitivity Tap the microphone to ensure that it is functioning. The fixture should react when in sound activation mode.
One of the control channels is unresponsive or only responds intermittently.	Damaged step motor or cable connection.	Contact your Martin™ authorized distributor or service center for assistance.

Symptom	Potential cause	Remedies
Fixture does not respond to DMX control.	Fault in the DMX network due to connector or cable damaged, or incorrect DMX addressing, or potential interference from proximity to a high voltage installation.	<p>Check that the fixture DMX LED is on, and if not, check all DMX cables and connections to ensure the integrity of the physical link. Ensure that the DMX link is terminated.</p> <p>Check that all devices on the DMX link use standard DMX polarity.</p> <p>Ensure that the fixture is set to the correct DMX address, one that matches that set on the DMX control device.</p> <p>Check the pins on the connectors from the previous fixture on the DMX link.</p> <p>Try to control the fixture with another DMX control device.</p> <p>Move the fixture if it is being operated very close to an unshielded high-voltage installation.</p>

# Specifications

## Physical

Weight .....9.6 kg (21.1lbs.)  
 Dimensions.....588 x 303 x 193 mm (23.1 x 11.9 x 7.6 in.)

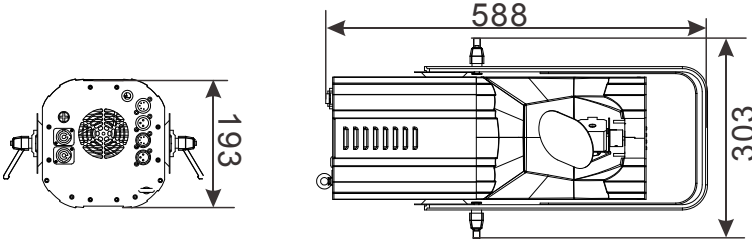

## Dynamic Effects

Color wheel 1.....8 colors plus open, rotation with variable direction and speed  
 Color wheel 2.....8 colors (incl. 1 x UV, 2 x CTC) plus open, rotation with variable direction and speed  
 Rotating gobo wheel.....6 gobos plus open  
 Fixed gobo wheel .....7 gobos plus open  
 Electronic 'shutter' effect ..... Strobe, pulse effects, instant open and blackout  
 Prism ..... Indexing and rotation with variable direction and speed  
 Focus.....Motorized  
 Electronic dimming .....0 - 100%, four dimming curve options  
 Pan ..... 170°, coarse & fine control  
 Tilt..... 75°, coarse & fine control

## Control and Programming

Control options ..... DMX, standalone, synchronized master/slave  
 DMX channels ..... 16  
 Standalone trigger options ..... Sound activation (music trig), auto trig  
 Standalone sequences..... 9 pre-programmed shows  
 Standalone memory ..... 20 scenes  
 Music trig sensitivity ..... Adjustable  
 Setting and addressing..... Control panel with backlit LCD display  
 DMX compliance ..... USITT DMX512/1990

## Optics and Photometric Data

Light source ..... 90 W LED engine  
 Minimum LED lifetime .....30 000 hours (to >70% luminous output)\*  
 Rotating gobo size..... 24 mm (0.94 in.)  
 Rotating gobo image size..... 20 mm (0.79 in.)

*\*Manufacturer's figure obtained under manufacturer's test conditions*



## Construction

Color ..... Black  
Housing ..... High-impact flame-retardant thermoplastic  
Protection rating ..... IP 20

## Installation

Mounting points ..... Adjustable bracket, surface or truss mount  
Location ..... Indoor use only, must be fastened to surface or structure  
Orientation ..... Any

## Connections

AC power input ..... Neutrik PowerCon  
AC power throughput ..... Neutrik PowerCon  
DMX data in/out ..... 3-pin & 5-pin locking XLR

## Electrical

AC power ..... 100-240 V nominal, 50/60 Hz  
Power consumption ..... 168 W  
Typical half-cycle RMS inrush current at 240 VAC ..... 10 A  
Fuse ..... T 6.3 A  
Power supply unit ..... Auto-ranging electronic switch mode

## Typical power and current

100 V, 60 Hz ..... 1.7 A, 170 W, PF 0.997  
120 V, 60 Hz ..... 1.4 A, 165 W, PF 0.994  
230 V, 50 Hz ..... 0.7 A, 162 W, PF 0.937

*Figures obtained at nominal voltage. Figures are typical, not maximum, allow for +/- 10% variation*

## Thermal

Cooling ..... Forced air  
Maximum ambient temperature ( $T_a$  max.) ..... 40° C (104° F)  
Minimum ambient temperature ( $T_a$  min.) ..... 0° C (32° F)  
Total heat dissipation ..... 570 BTU/hr.\*

*\*Calculated, +/- 10%, at full intensity*

## Approvals



EU safety ..... EN 60598-2-17 (EN 60598-1), EN 62471, EN 62493  
EU EMC ..... EN 55015, EN 55103-1, EN 55103-2,  
EN 61000-3-2, EN 61000-3-3, EN 61547  
US safety ..... UL 1573  
US EMC ..... FCC Part 15 Class B

Canadian safety .....	CSA C22.2 No. 166
Canadian EMC .....	ICES-003 Class A
Australia/NZ.....	RCM

**Included Items**

- Power cable, 6 A, 18 AWG, 0.75 mm<sup>2</sup>, UL- listed, H05VV-F, 1.5 m, without mains plug
- Mounting bracket

**Accessories**

*Cables, 16 A, for connection to power in chains*

- Power input cable, 14 AWG, SJT, 1.5 mm<sup>2</sup>, H05VV-F, with PowerCon input connector, 3 m (9.8 ft.)..... P/N 11541508
- Power relay cable, 14 AWG, SJT, 1.5 mm<sup>2</sup>, H05VV-F, with PowerCon connectors, 1.4 m (4.6 ft.)..... P/N 11541509
- Power relay cable, 14 AWG, SJT, 1.5 mm<sup>2</sup>, H05VV-F, with PowerCon connectors, 2.25 m (7.4 ft.)..... P/N 11541510
- Power relay cable, 14 AWG, SJT, 1.5 mm<sup>2</sup>, H05VV-F, with PowerCon connectors, 3.25 m (10.7 ft.)..... P/N 11541511

*Power connectors*

- Neutrik PowerCon NAC3FCA power input connector, cable mount, blue ..... P/N 05342804
- Neutrik PowerCon NAC3FCB power output connector, cable mount, light grey ..... P/N 05342805

*Installation hardware*

- Half-coupler rigging clamp..... P/N 91602005
- Safety cable, SWL 60 kg, BGV C1 / DGUV 17, black..... P/N 91604006
- Safety cable, SWL 60 kg, BGV C1 / DGUV 17, silver..... P/N 91604007



**Related Items**

- RUSH™ Software Uploader 1..... P/N 91611399

**Ordering Information**

- RUSH™ Scanner 1 LED in cardboard box ..... P/N 90480120

*Specifications are subject to change without notice. For the latest product specifications, see [www.martin.com](http://www.martin.com)*

 	<p><b>Disposing of this product</b></p> <p>Martin™ products are supplied in compliance with Directive 2012/19/EC of the European Parliament and of the Council of the European Union on WEEE (Waste Electrical and Electronic Equipment), where applicable. Help preserve the environment! Ensure that this product is recycled at the end of its life. Your supplier can give details of local arrangements for the disposal of Martin products</p>
--	--

**Photobiological Safety Warning**

The label shown below is displayed on this product. If it becomes difficult or impossible to read, it must be replaced using the illustration below to reproduce a new label sized 45 x 35 mm, in black on a yellow background.

<p><b>Risk Group 2</b></p>
<p>CAUTION. Possibly hazardous optical radiation emitted from this product. Do not stare at operating lamp. May be harmful to the eyes.</p>
<p><b>Groupe de risque 2</b></p>
<p>PRUDENCE. Produit à émission de radiations visibles potentiellement dangereuses. Ne pas fixer le faisceau en fonctionnement. Risque de lésions oculaires.</p>











---

[www.martin.com](http://www.martin.com) · Olof Palmes Allé 18 · 8200 Aarhus N · Denmark  
Tel: +45 8740 0000 · Fax +45 8740 0010